

High-Performance Door

ASSA ABLOY RR392

ASSA ABLOY

ASSA ABLOY Entrance Systems

The global leader in
door opening solutions



ASSA ABLOY RR392

- Robust industrial door that offers good value for money
- Self-opening (depending on door size) once the brake has been released by the built-in counterweights
- Optional knock-out capability also available

DOOR MATERIAL

The side frames of the door consist of galvanised steel profiles.

DOOR CURTAIN

As standard the door is equipped with a transparent curtain with blue (RAL 5002) reinforcement stripes. Further colours for the reinforcement stripes are optionally available: red (RAL 3002), beige (RAL 1014), yellow (RAL 1021), orange (RAL 2011), green (RAL 6018), white (RAL 9016) and grey (RAL 7035).



ALTERNATIVE CURTAINS / WINDOWS

Alternatively a curtain made of Roll-Tex® Plus is available in the following colours: orange (RAL 2009), blue (RAL 5002) and grey (RAL 7001). The insert of a window for improved visibility is optional.



SAFETY FEATURES

The door has an electric safety contact edge. A door line photocell also prevents the door closing when objects or people are in the way.

KNOCK-OUT CAPABILITY

The door can be fitted with an optional knock-out capability. In the event of a crash, the bottom profile swivels out and a sensor stops the door. Mounting can then easily be done by hand. Doors with knock-out feature are equipped with a spiral cable. Integrated cable guidance is feasible for doors without knock-out feature and are optionally available.

BOTTOM PROFILE

The bottom profile is made of aluminium. It can be fitted with an extended seal to improve the sealing properties e.g. when the floor is uneven.



ACTUATORS

Depending on each individual application various additional safety-devices like infrared or radar detectors and all kind of industrial actuators (push button, vehicle detector loops, radio transmitter) can be added to the control system. Please contact us for counselling and providing your individual configuration.





TOP ROLL COVER

The basic model of the door is supplied without a cover for the top roll.

A model with chamfered profiles is available as an option.



MOTOR COVER

Basic version supplied without cover.

An optional plastic cover is available for the drive unit.



MOTOR POSITION

The motor can be fitted on the left or right depending on the customer's choice.

TOP ROLL

Doors up to a width of 4500 mm are equipped with a top roll made of aluminum, any door exceeding this width comes with a top roll made of steel.

CHAIN DRIVE

An optional chain drive can be used when space is at a premium at the sides. It is fitted in front of the side frames.

CONTROL UNIT

Two control systems are available as option depending on the desired opening speed, supply voltage and activator requirements to operate the door. The basic contactor control ACS 50 as well as the innovative frequency converter control MCC for an especially smooth run. The MCC control unit is installed directly under the drive unit. The control panel of the MCC control unit with convenient foil keys and a graphic display can be fixed on the side frame or on the wall. Comprehensive diagnoses and error codes are available on the display.



High-Performance Door ASSA ABLOY RR392

Advantages of ASSA ABLOY RR392

- curtain guides in the side frames protect the material and offer high wind resistance and a long service life
- fast opening and closing minimises energy and temperature loss
- door curtain made of high-transparency PVC or very rigid RollTex® Plus for extreme mechanical demands
- robust industry standard at attractive value for money
- solid basic design that can be upgraded individually as required

Application

- as an exterior door to prevent drafts and for access control
- as a room and environment divider to save energy indoors
- in busy transport locks

Design

Self-supporting, easy-to-install design of bevel-edged steel profiles. A counterbalance in the form of counterweights is integrated in the side frames. The top roll is made of aluminium for doors up to 4500 mm wide and steel for wider doors. The bottom profile is made of aluminium and can be fitted with an optional knock-out capability.

Door Curtain

The door has a curtain of clear PVC with blue vertical reinforcement fabric stripes. Alternatively, for applications with greater mechanical demands, a curtain of RollTex® Plus fabric can be used. Windbreak taps are fitted to the door curtain for wind load resistance, which hold the curtain in the side frame profiles even under a heavy wind load. A curtain tension system is fitted as standard to the ASSA ABLOY RR392.

Drive Unit

The drive unit is a geared brake motor. It can be fitted on the right or left.

Control System

The door is fitted with an ACS 50 control unit as standard. The innovative frequency converter control system MCC for smooth, dynamic door operation is optionally available.

Knock-out Capability

The door can be fitted with an optional knock-out capability. In the event of a collision, the bottom profile swivels out and a sensor causes the door to stop. Mounting can then easily be done by hand.

Manual Activation

In the event of a power failure, the door can be opened by releasing the brake and manually lifting the bottom profile. The weights in the counterbalance act as a support.

Safety Features

The door is designed according to the Workplace Directive of the UVV regulations and the harmonized CE Guidelines including the EN 13241-1.

Indication of Risk

The safety features of the door conform to the product standards and the corresponding harmonised CE-guidelines for power-operated doors. In consideration of the situation on site – especially in case of use by pedestrians – additional safety measures, like additional actuators may be required. In addition, special environmental conditions may have impact on the right choice of doortype. In case of any doubt, please contact our sales engineer to receive consulting on site.

- option
- ✓ standard
- not available

- ¹⁾ For doors of height ≤ 2500 mm the use of top roll and motor cover is required according to standard EN 13241-1.
- ²⁾ 16 A bei 220/230 V
- ³⁾ recommended 10 A, max. 16 A
- ⁴⁾ Transformator necessary for 440/480/500V
- ⁵⁾ Transformator necessary for 220/230/500V

TECHNICAL DATA

Interior door	suitable
Exterior door	suitable
Wind resistance	class 2 - EN 12424
Door dimension (mm)	(For details please note general drawing)
(DW min./max.)	2000 / 6000 mm
(DH min./max.)	2000 / 6000 mm
Opening direction	vertical

Surface	
Side frames	galvanised steel profile
Bottom profile	anodised aluminium
Top roll	≤ B 4500 mm aluminium > B 4500 mm primed steel
Covers (optional)	
Top roll cover	• ¹⁾
Motor cover	• ¹⁾
Door curtain (alternatively)	
PVC with blue reinforcement stripes	✓
PVC with coloured reinforcement stripes	•
PVC with silicon-free reinforcement stripes: blue (RAL 5010), white (RAL 9010), alugrey (RAL 7037), yellow (RAL 1021) red (RAL 3002) black (RAL 9005) or orange (RAL 2011)	•
RollTex® Plus (fabric that is stiff across the grain) with/without window	•
Wind taps	✓
Curtain tension	✓
Counterbalance	✓

Control system / Drive unit	
Drive unit	electrical
Chain drive	•
ACS 50	✓
MCC	•
Motor power / kW	1,1 kW

Safety	
Electric safety contact edge	✓
Door line photocell	✓
Fall down protection	✓ via counterweights
Knock-out capability	•
Self-opening	depending on size
Manual activation	✓ with bowden lever operated from the floor
Second bowden lever	•
Extended seal	•
integrated cable guidance	•

Speed (m/s)	ACS 50	MCC
Open/close up to max.	0,8/0,8	2,2/0,9
Fuse protection	10 A ²⁾	10 A ³⁾
Control voltage	24 V DC	24 V DC
Protection degree	IP 55	IP 55
3L(N)/PE 220/230/380/400/415V; 50 Hz	✓ ⁴⁾	
3L(N)/PE 380/400/415/440/480V; 50/60 Hz		✓ ⁵⁾
Additional opening heights	–	•
Potential free contacts max. 250 V	✓	•

Traffic light function		
Without direction detection	✓	✓ 24 V DC
With direction detection	–	✓ 24 V DC
Flashing alarm light	✓	✓ 24 V DC
Error message	✓ LEDs	✓ plaintext

General drawing ASSA ABLOY RR392

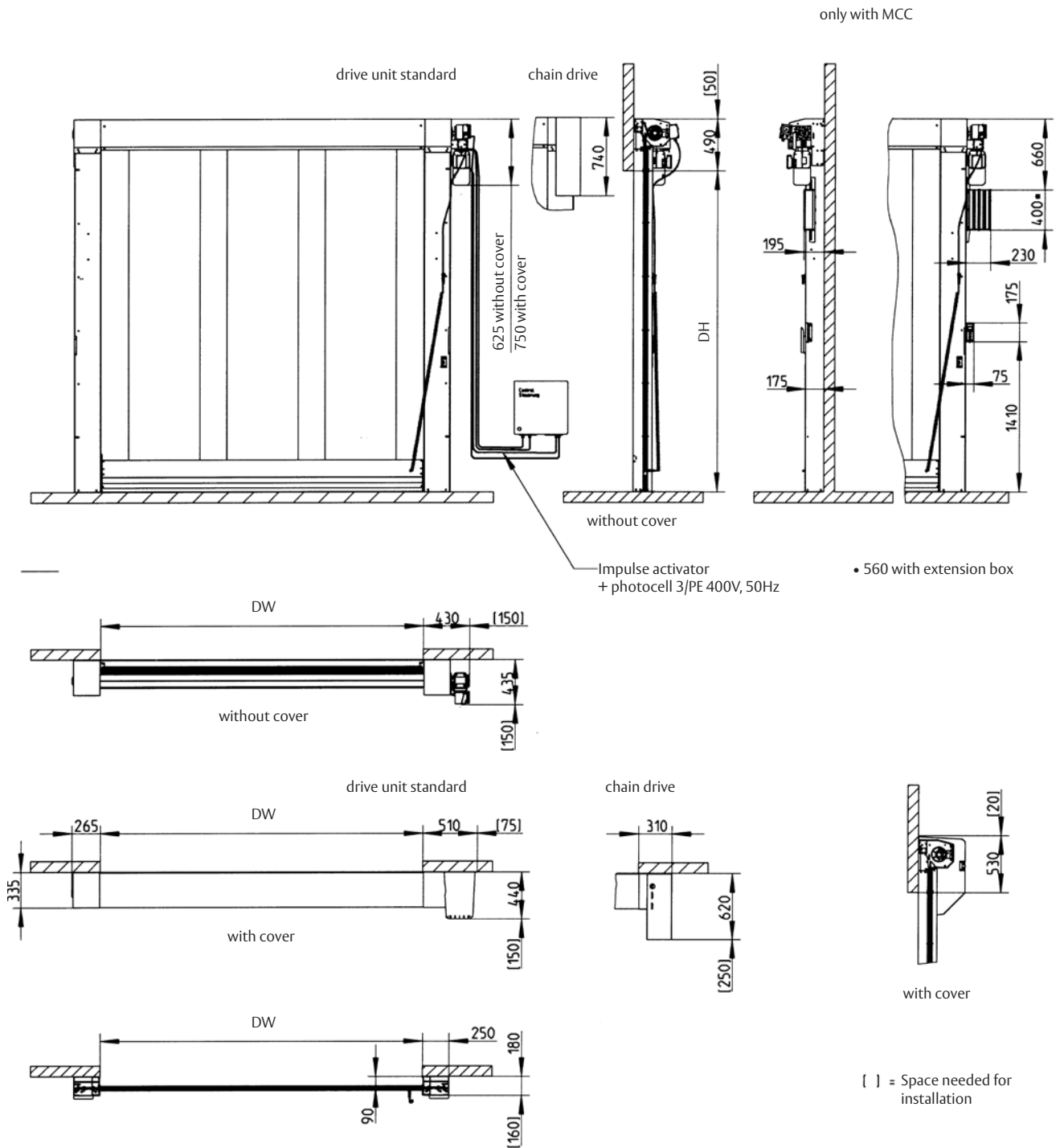

ASSA ABLOY Entrance Systems is a leading supplier of entrance automation solutions for the efficient flow of goods and people. Building on the long-term success of the Besam, Crawford, Albany and Megadoor brands, we offer our solutions under the ASSA ABLOY brand. Our products and services are dedicated to satisfying end-user needs for safe, secure, convenient and sustainable operations.
ASSA ABLOY Entrance Systems is a division of ASSA ABLOY.

assaabloyentrance.com

Fixing plan ASSA ABLOY RR392

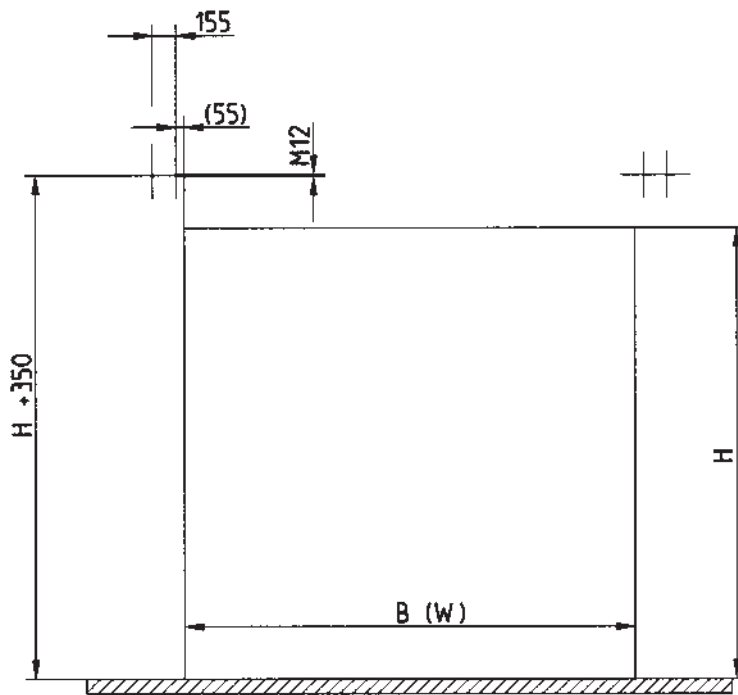

Fixing over lintel

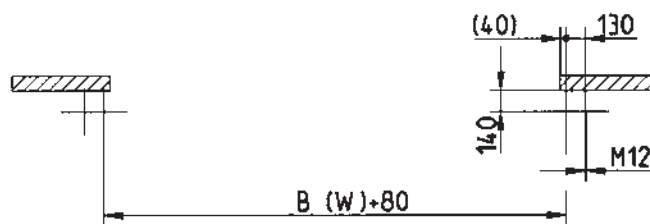

Fixing to floor

8300R0002/a



ASSA ABLOY Entrance Systems

info.entrance@assaabloy.com
assaabloyentrance.com

Follow us:



Please enter ASSA ABLOY Entrance in the channel's search field.